

Radio control model / Flugmodell

BEECHCRAFT

# T-34C TURBO MENTOR

MILITARY TRAINER



VQ No: VQA137

ALL Balsa, PLYWOOD CONSTRUCTION AND ALMOST READY TO FLY

## Instruction manual / Montageanleitung

### SPECIFICATIONS

Wingspan:.....1560mm (61.4in)  
Length:.....1170mm (46 in)  
Electric Motor:.....See next pager  
Glow Engine:......46 2-T / .70 4-T  
RTF Weight: 3.2Kg / 7.05lbs (Will vary with  
Equipment Used).  
Radio:.....6 Channel / 6-7 Servos  
Function: Ailerons-Elevator-Rudder-Throttle  
Flaps-Optional Retractable Landing Gear.

### TECHNISCHE DATEN

Spannweite:.....1560mm  
Länge:.....1170mm  
Elektroantrieb.....(siehe nächste Seite)  
Verbrennerantrieb:.....7.45cc - 11.5cc  
Fluggewicht:.....3.2Kg  
Fernsteuerung.....6 Kanal / 6-7 Servos

# PICHLER

ARF BY



**WARNING!** This radio controlled model is NOT a toy. If modified or flown carelessly it could go out of control and cause serious human injury or property damage. Before flying your airplane, ensure the air field is spacious enough. Always fly it outdoors in safe areas and seek professional advice if you are unexperienced.

**ACHTUNG!** Dieses ferngesteuerte Modell ist KEIN Spielzeug! Es ist für fortgeschrittene Modellflugpiloten bestimmt, die ausreichende Erfahrung im Umgang mit derartigen Modellen besitzen. Bei unsachgemäßer Verwendung kann hoher Personen- und/oder Sachschaden entstehen. Fragen Sie in einem Modellbauverein in Ihrer Nähe um professionelle Unterstützung, wenn Sie Hilfe im Bau und Betrieb benötigen. Der Zusammenbau dieses Modells ist durch die vielen Abbildungen selbsterklärend und ist für fortgeschrittene, erfahrene Modellbauer bestimmt.

**REQUIRED FOR OPERATION (Purchase separately) More info: [www.pichler-modellbau.de](http://www.pichler-modellbau.de)**

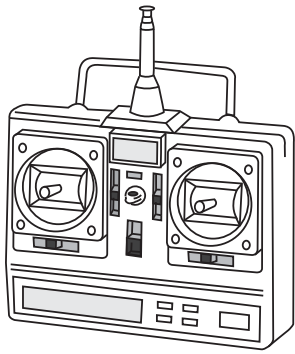

10.5x6 for .40 - 2 cycle engine  
 11x6 for .46 - 2 cycle engine  
 12x6 for .60 - 4 cycle engine  
 12x7 for .70 - 4 cycle engine  
 13x7 for electric motor

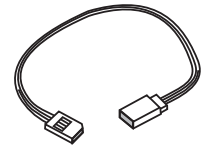

Extension for aileron servo, retract servo and Rx battery pack.

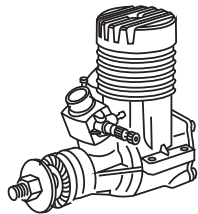
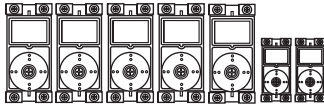

.46 ~ .50 - 2 cycle

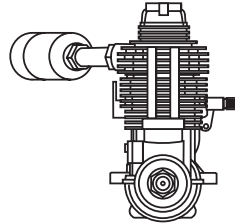

.60 ~ .70 - 4 cycle

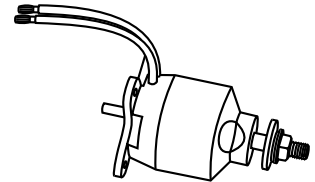

Minimum 6 channel radio for airplane with 5 (4 for EP) standard servos and two servo mini.

.Motor control x1(for GP) .Elevator x1  
 .Rudder x1. Aileron x2. Flapx2 mini servo



Silicone tube

**Antrieb Tuning (Kraftvoller Kunstflug):**

BOOST 60 Brushless Combo Set, Best.Nr. C3174  
 LiPO Akku RED POWER 4250-5S, Best.Nr. C4547  
 Luftschraube 13\*8, Best.Nr. C2846

**GLUE (Purchase separately)**



Silicon sealer

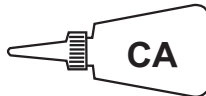

Cyanoacrylate Glue



Epoxy Glue ( 5 minute type)



Epoxy Glue (30 minute type)

**TOLLS REQUIRED (Purchase separately)**

Hobby knife 

Phillip screw driver 

Hex Wrench 

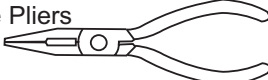
Needle nose Pliers 

Scissors 

Awl 

Sander 

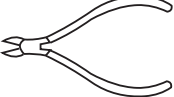
Wire Cutters 

Masking tape - Straight Edged Ruler - Pen or pencil - Drill and Assorted Drill Bits

If exposed to direct sunlight and/or heat, wrinkles can appear. Storing the model in a cool place will let the wrinkles disappear. Otherwise, remove wrinkles in covering film with a hair dryer, starting with low temperature. You can fix the corners by using a hot iron.

Bei Sonneneinstrahlung und/oder Wärme kann die Folie erschlaffen bzw. Falten entstehen. Verwenden Sie ein Warmluftgebläse (Haartrockner) um evtl. Falten aus der Folie zu bekommen. Die Kanten können Sie mit einem Bügeleisen behandeln. Nicht zuviel Hitze anwenden !

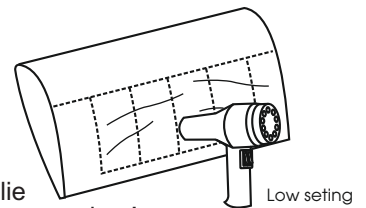



Symbols used throughout this instruction manual, comprise:

 Drill holes using the stated size of drill (in this case 1.5 mm  $\dot{y}$ )

 Take particular care here

 Hatched-in areas: remove covering film carefully

 Check during assembly that these parts move freely, without binding

 Use epoxy glue

 Apply cyano glue

 Assemble left and right sides the same way.

 Not included. These parts must be purchased separately

 Löcher bohren mit dem angegebenen Bohrer (hier 1,5 mm)

 Hier besonders aufpassen

 Schraffierte Stellen, Bespannfolie vorsichtig entfernen

 Während des Zusammenbaus immer prüfen, ob sich die Teile auch reibungslos bewegen lassen

 Epoxy-Klebstoff verwenden

 Sekundenkleber auftragen

 Linke und rechte Seite wird gleichermaßen zusammgebaut

 Nicht enthalten. Teile müssen separat gekauft werden.

**Read through the manual before you begin, so you will have an overall idea of what to do.**

**CONVERSION TABLE**

1.0mm = 3/64"	3.0mm = 1/8"	10mm = 13/32"	25mm = 1"
1.5mm = 1/16"	4.0mm = 5/32"	12mm = 15/32"	30mm = 1-3/16"
2.0mm = 5/64"	5.0mm = 13/64"	15mm = 19/32"	45mm = 1-51/64"
2.5mm = 3/32"	6.0mm = 15/64"	20mm = 51/64"	

# 1-Aileron and Flap servo

WING - BOTTOM VIEW

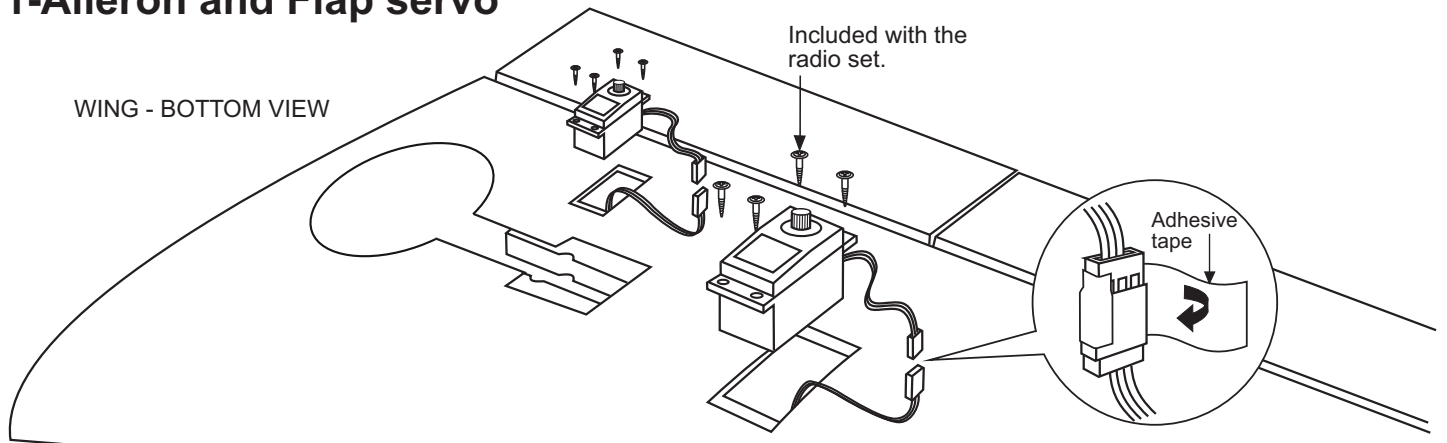

- 1-Cut away the covering of the wing bottom where the aileron servo goes.
- 2-Connect the aileron servo cord to the aileron extension cord.
- 3-Install the aileron servo on the servo mount.

Do the same way with second wing half.

-Switch on the radio (trims centered) then mount the ailerons servo in neutral position.  
 -The servo horn should be perpendicular to the servo

**YES**      **NO**

# 2-Aileron/Flap control horn

WING - BOTTOM VIEW

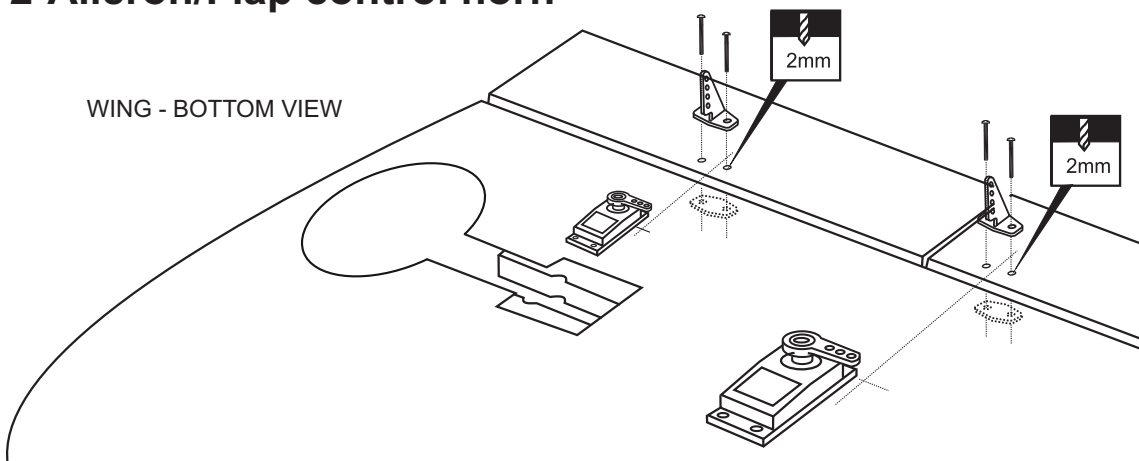

Plastic control horn

	.....4
	2x30mm...8
	.....4

Control horn Alignment

- 1-Depending on the position of the linkage, determine the location of aileron control horn. The horn holes must be perfectly aligned with the axis of articulation.
- 2-Mark the position of the "foot" of the horn on the aileron. Then, with the drill, make the 2 holes.
- 3-Install the aileron control horn as shown.

Do the same way with second wing half.

# 3-Aileron/Flap linkages

WING - BOTTOM VIEW

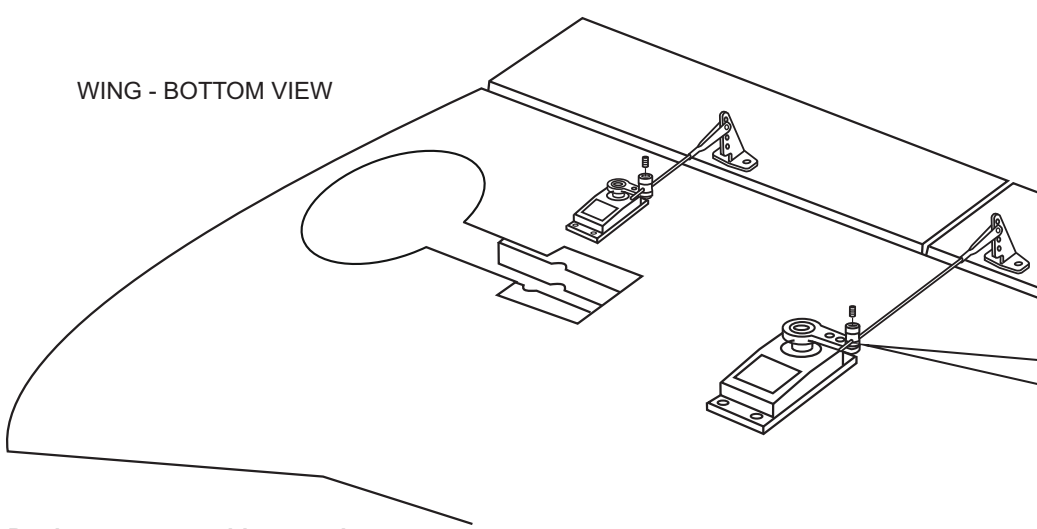

3mm set Screw

Aileron pushrod D=5/64" (2mm)

2 mm

X

Do the same way with second wing half.

## 4-Electric retract

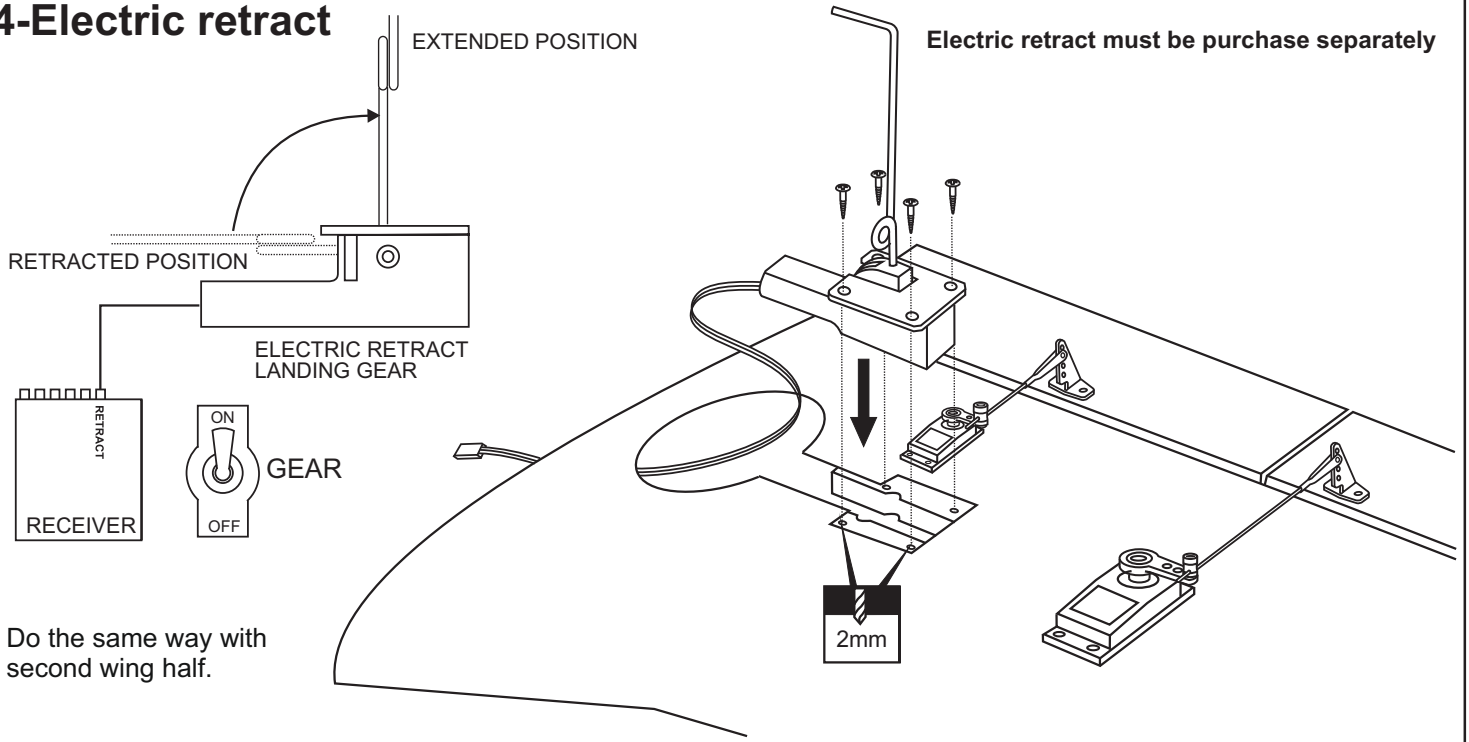

## 5-Fixed gear

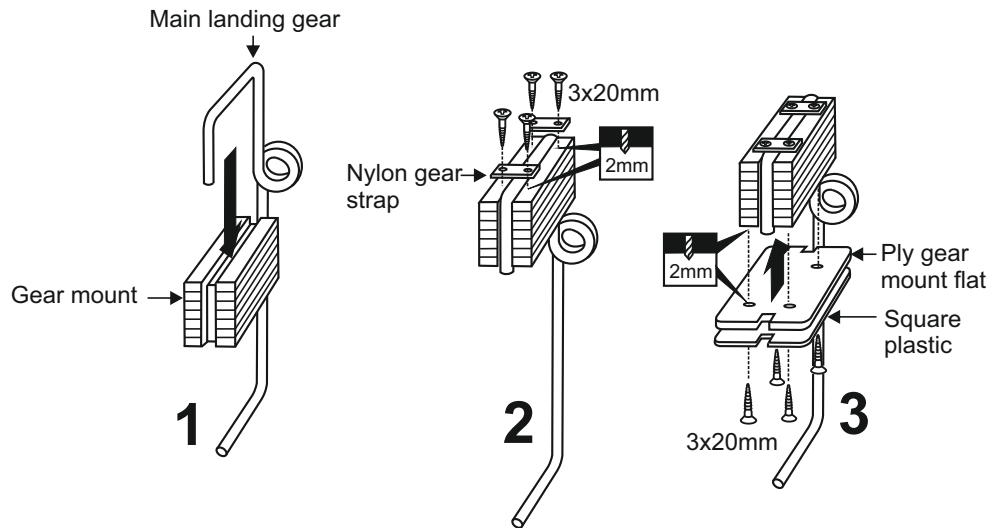
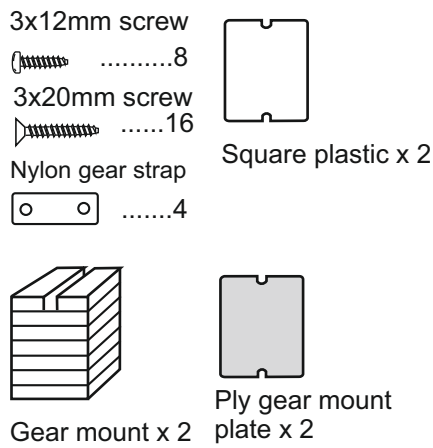

## 6-Fixed gear installation

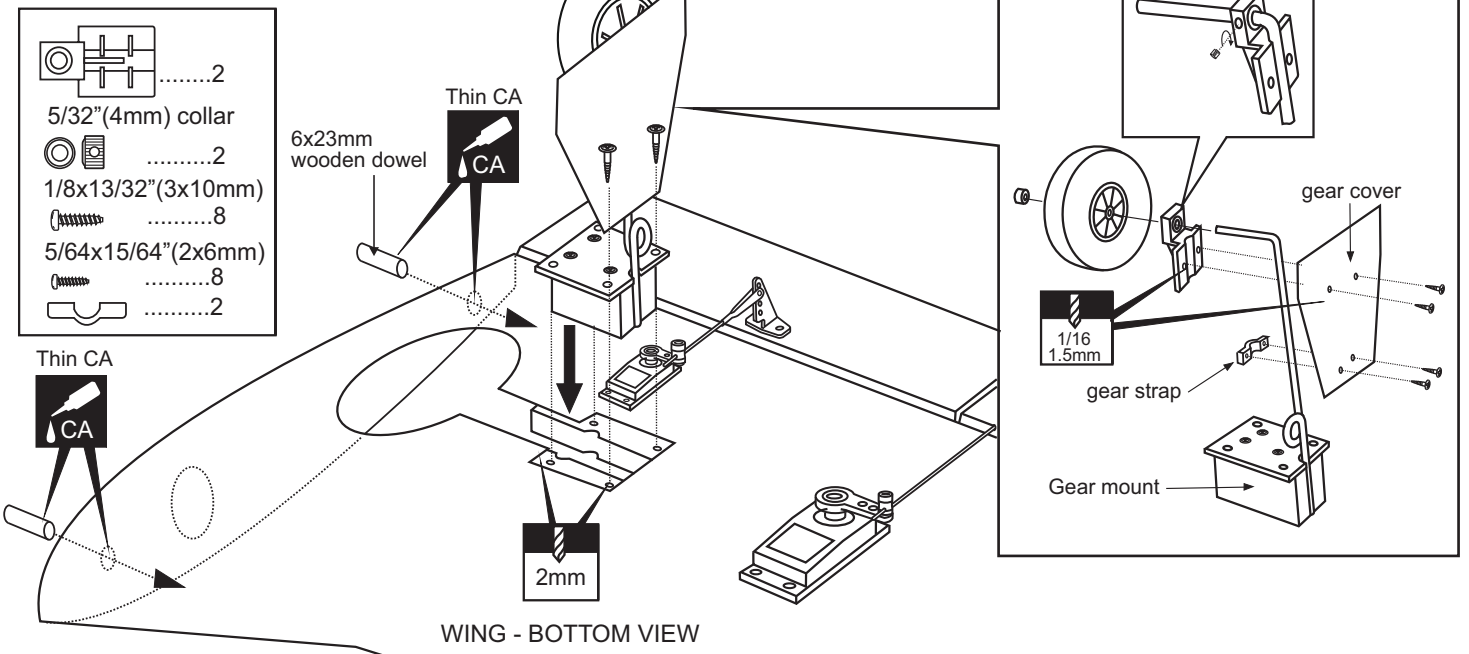

## 7-Horizontal Stabilizer

Securely glue together. If coming off during flight, you lose control of your air plane.

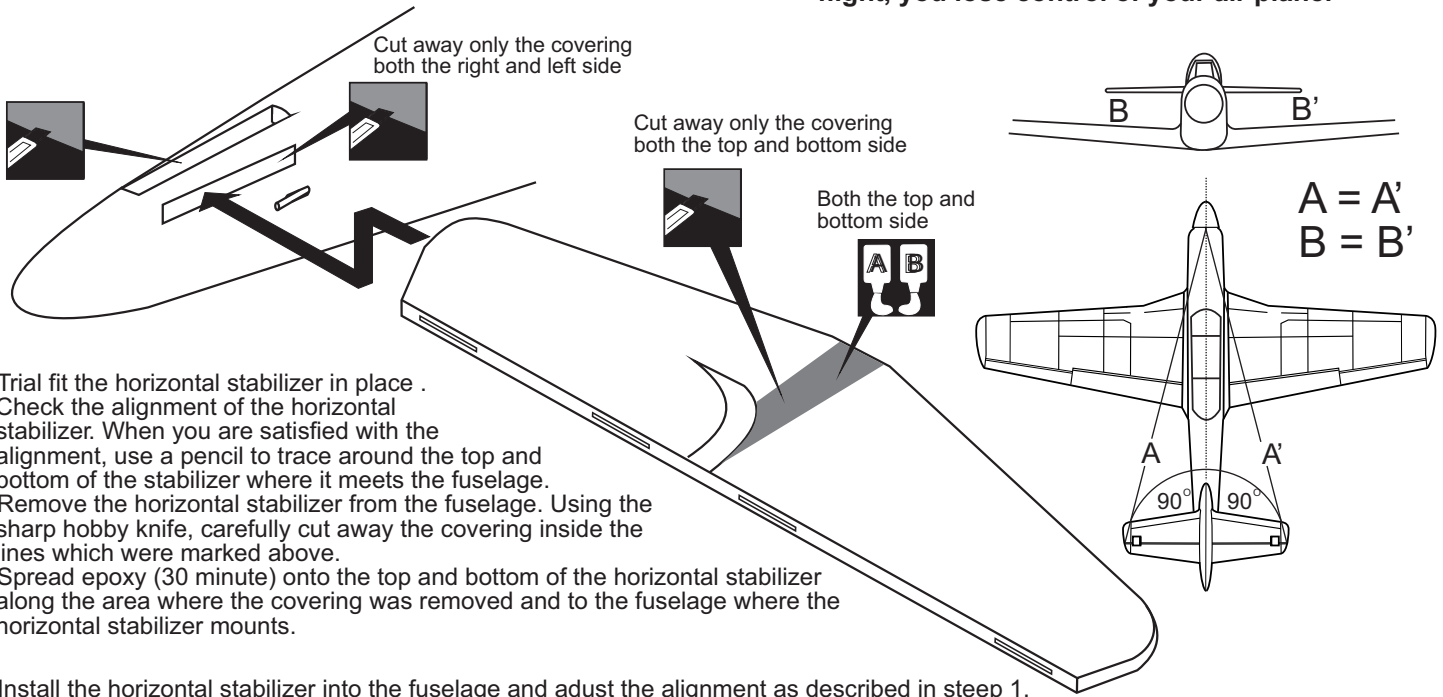

- 1-Trial fit the horizontal stabilizer in place . Check the alignment of the horizontal stabilizer. When you are satisfied with the alignment, use a pencil to trace around the top and bottom of the stabilizer where it meets the fuselage.
- 2-Remove the horizontal stabilizer from the fuselage. Using the sharp hobby knife, carefully cut away the covering inside the lines which were marked above.
- 3-Spread epoxy (30 minute) onto the top and bottom of the horizontal stabilizer along the area where the covering was removed and to the fuselage where the horizontal stabilizer mounts.

4-Install the horizontal stabilizer into the fuselage and adjust the alignment as described in step 1.

**IMPORTANT:** Please do not clean off the excess epoxy with strong solvent or pure alcohol, only use kerosene to keep the colour of your model not fade.

**\* WARNING:** When removing any covering from the airframe, please ensure that you secure the cut edge with CA or similar cement. This will ensure the covering remain tight.

## 8-Vertical Stabilizer

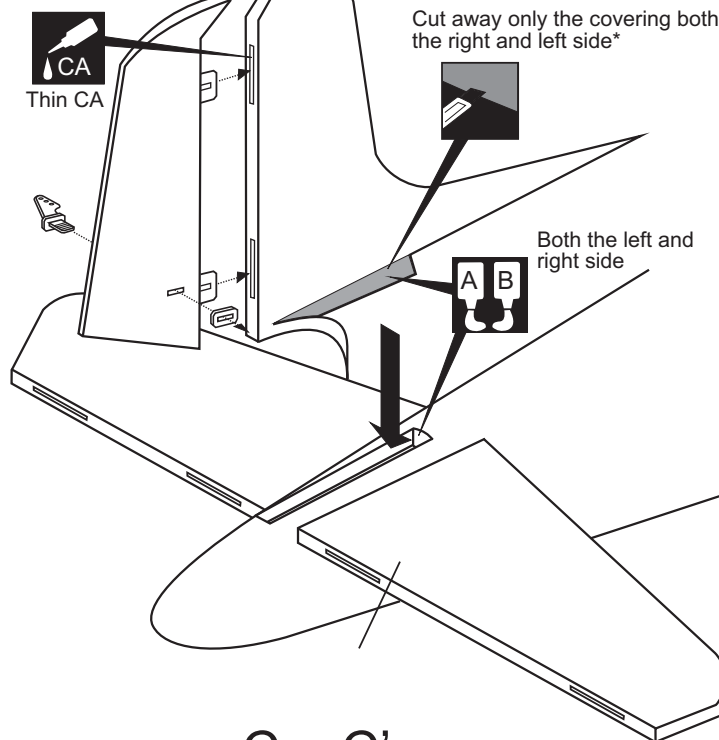
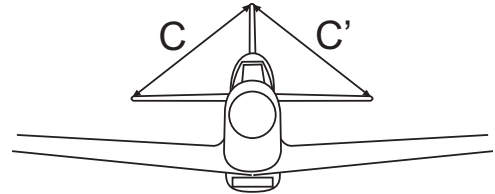

- 1-Trial fit the vertical stabilizer in place . Check the alignment of the vertical stabilizer. When you are satisfied with the alignment, use a pencil to trace around the right and left of the stabilizer where it meets the fuselage.
- 2-Remove the vertical stabilizer from the fuselage. Using the sharp hobby knife, carefully cut away the covering inside the lines which were marked above.
- 3-Spread epoxy (30 minute) onto the right and left and bottom of the vertical stabilizer along the area where the covering was removed and to the fuselage where the vertical stabilizer mounts.

4-Install the vertical stabilizer into the fuselage and adjust the alignment as described in step 1. Allow the epoxy to cure before proceeding to next step.

5-Trial fit the horn. Actuate rudder linkage manually it should not be hard spot. Adjust if necessary.

6-Insert the plate through the foot of the horn. Bond with **thin CA glue**.

Note: The slots for the control horn installation are pre-cut at factory.

Securely glue together. If coming off during flight, you lose control of your air plane.

Plastic control horn

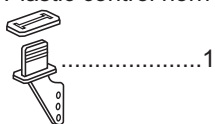

$C = C'$

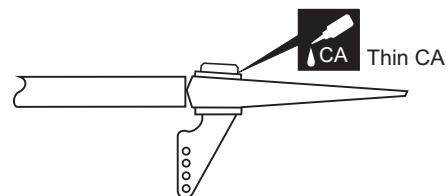
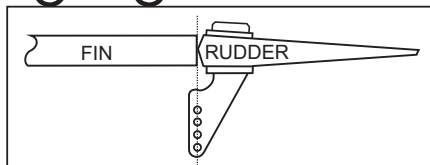



# 9-Elevator

Securely glue together. If coming off during flight, you lose control of your air plane.

- 1-Trial fit the horn. Actuate rudder linkage manually it should not be hard spot. Adjust if necessary.
- 2-Insert the plate through the foot of the horn. Bond with **thin CA glue**.
- 3-Repeat the previous procedures to hinge the second elevator to the other side of the horizontal stabilizer.

Note: The slots for the control horn installation are pre-cut at factory.

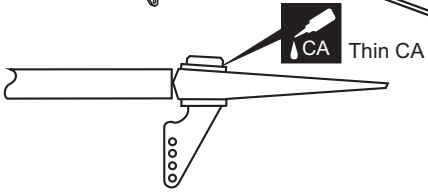
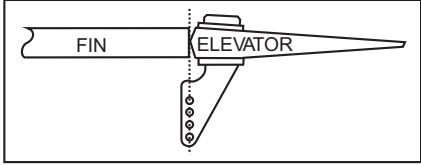
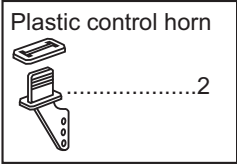
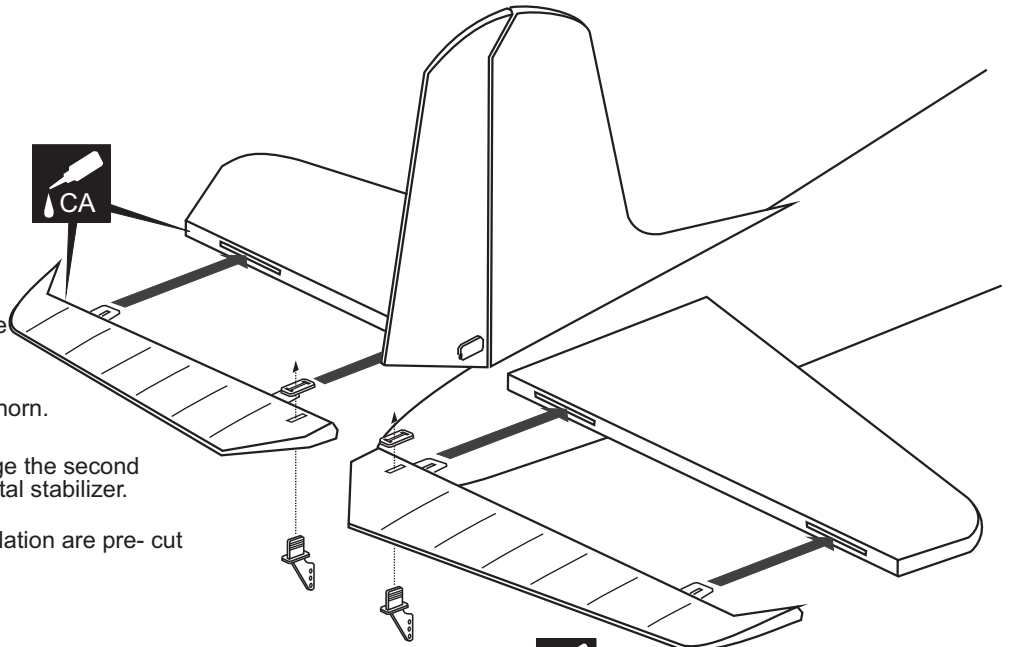

# 10-Nose gear

- Nose gear mount .....1
- 3x12mm screw...4
- 3mm nut, washer...4
- Steering arm...1

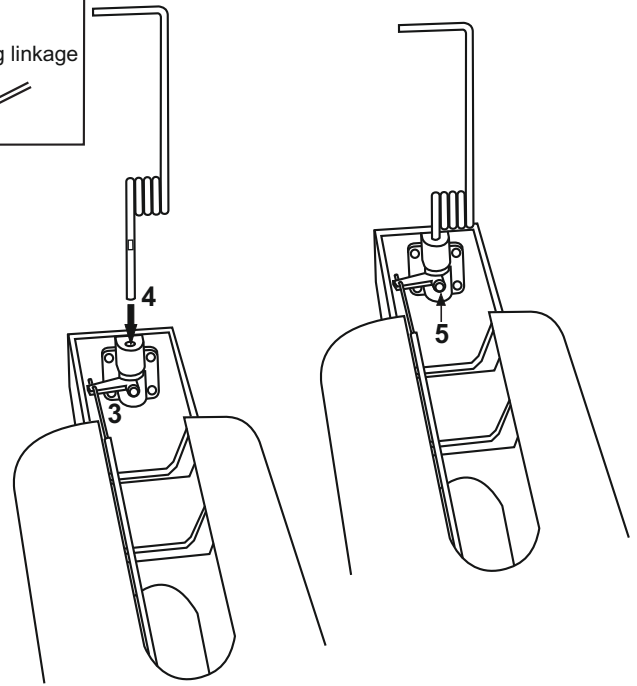
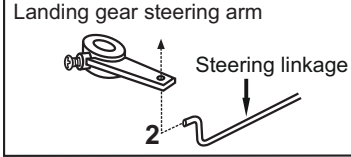
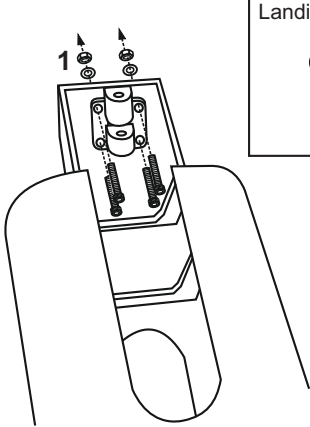

- 1- Route the steering linkage into the fuselage and through the fire-wall.
- 2- Insert "Z" bend of steering linkage inside the hole of front landing gear Steering arm.
- 3- Position the steering arm inside the front landing gear mount already Attached to the firewall.
- 4- Slide in the front gear leg with the flat to back through the bearing and steering arm.
- 5- Screw steering arm on the leg.

IN CASE OF ELECTRIC RETRACT LANDING GEAR  
**(Electric retract landing gear and Struts must purchase separately)**

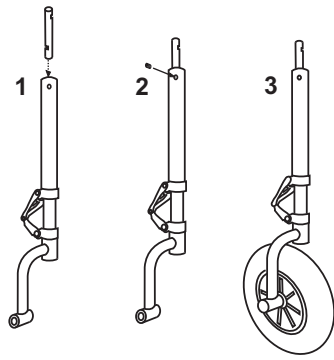
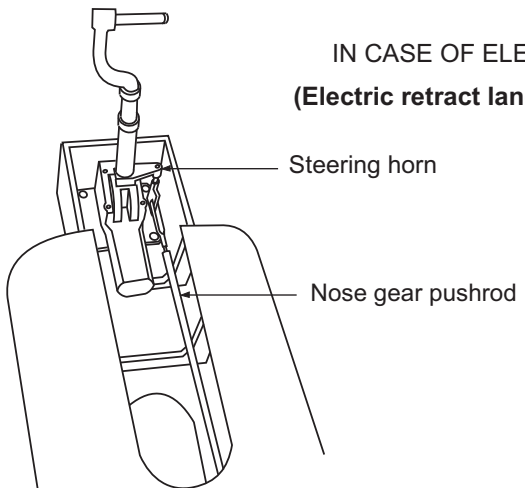

# 11-Engine mount / Engine

5/32x1"	1/8x5-1/64"
4x25mm screw	3x20mm screw
...4	...4
Blind-nut	1/8"(3mm) nut
.....	.....

! Align the mark on both mounts with the mark on the fuselage

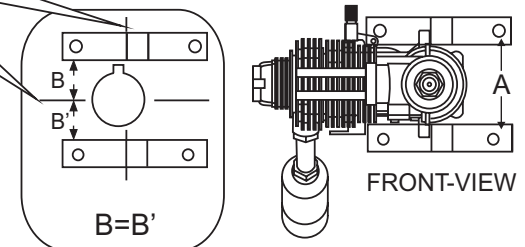

Using a pencil or felt tipped pen, mark the fire wall where the four holes are to be drilled.

Remove the engine mount and drill a 13/64"(5mm) hole through the fire-wall at each of the four marks marked.

Reposition the engine mounts on to the fire-wall. Attach the four blind-nut to the fire-wall as show. Secure them with four 4x25mm screw.

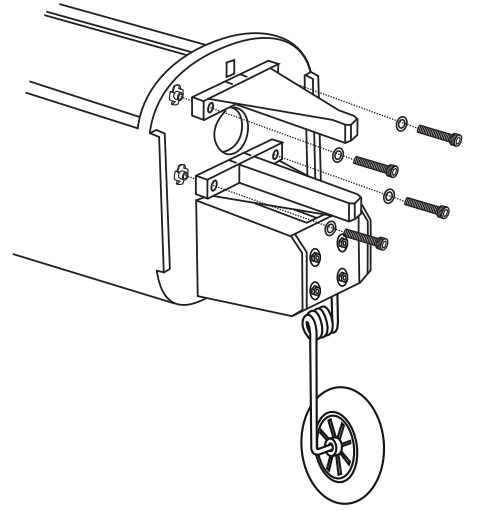
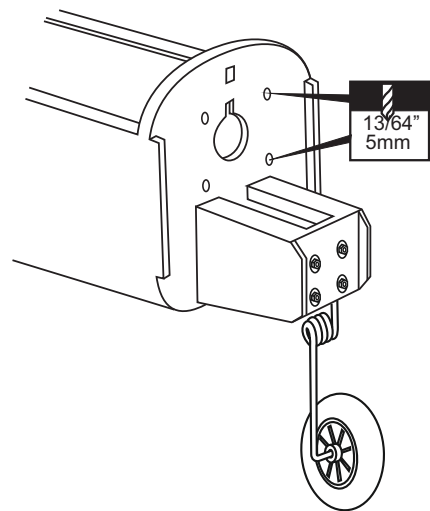
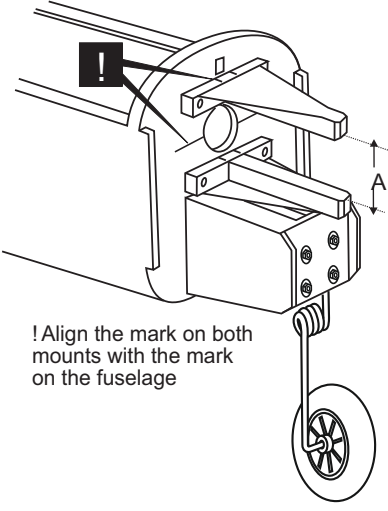

Position the engine on to the engine mounts so the distance from the prop hub to the fire-wall is 5.2"(132mm). Mark the engine mounting plate where the four holes are to be drilled.

Remove the engine and drill a 1/8"(3mm) holes through the beam at each of the four marks made above.

Reposition the engine on the engine mount beams, aligning it with the holes. Secure the engine to the engine mount using four 1/8x51/64"(3x25mm) screws.

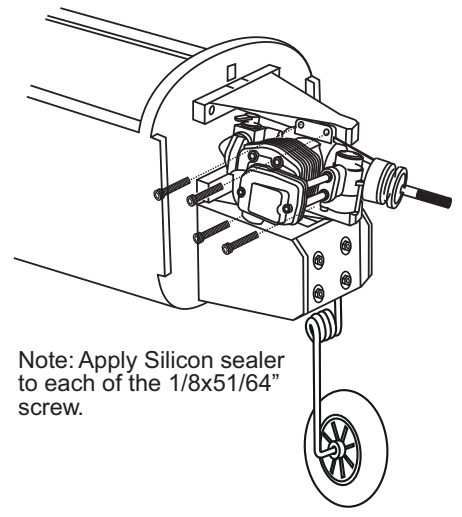
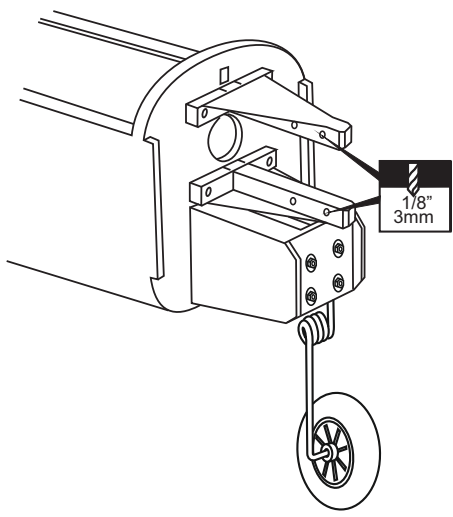
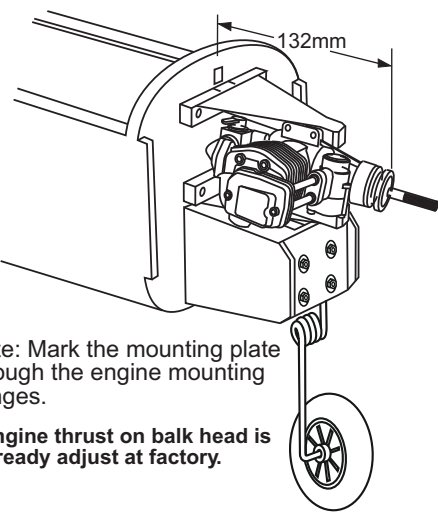

Note: Mark the mounting plate through the engine mounting flanges.  
! Engine thrust on balk head is already adjust at factory.

# 12-Fuel tank (in case of glow engine using)

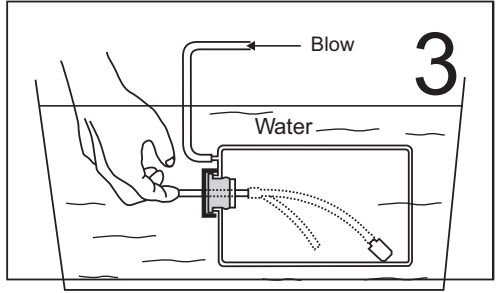
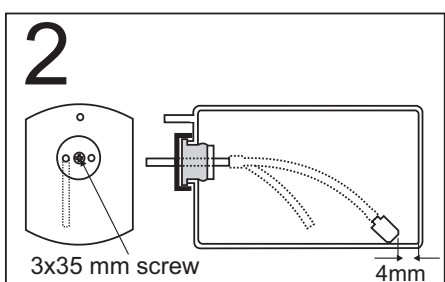
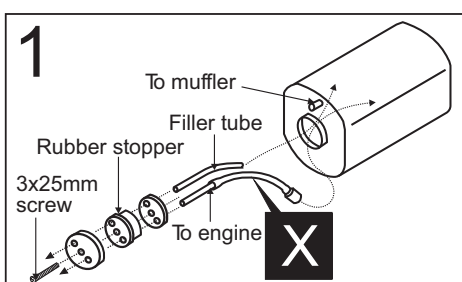

After confirming the direction . Insert this assembly, clunk end first, into the fuel tank and tighten and screw the fuel tank cap on firmly.  
Ensure that the fuel tank clunk does not touch the rear of the fuel tank.

Checking for leaks - block the vents and blow into the feed - if in doubt submersing the tank in a blow of water will show up any problems.

## 13-Electric Motor

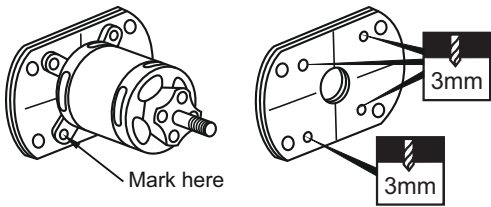

Using an aluminum motor mounting plate as a template, mark the plywood motor mounting plate where the four holes are to be drilled.

Remove the motor and drill a 3mm (1/8") hole at each of the four marks marked.

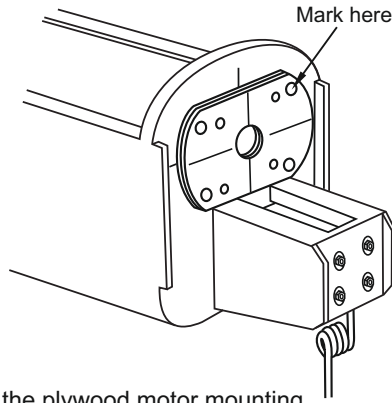

Apply the plywood motor mounting onto the fire-wall. Align the marks on the motor mounting with the marks on the fire-wall. Mark the fire-wall where the four holes are to be drilled.

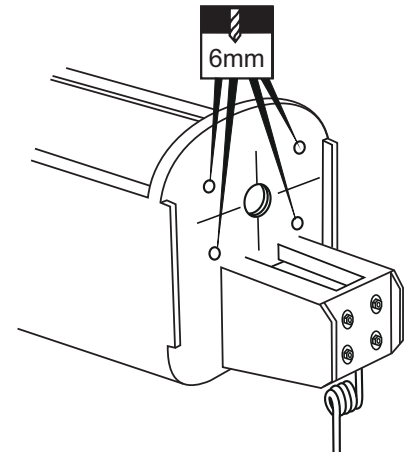

Remove the motor mounting and drill a 6mm hole at each of the four marks marked.

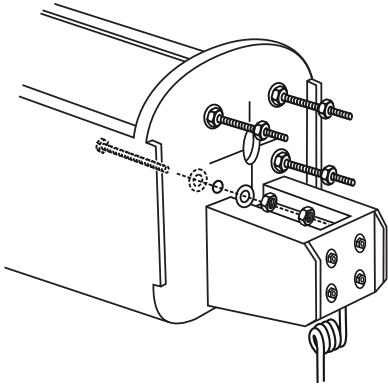

Attach the four 6x100mm bolts, washers and nuts to the fire-wall as shown.

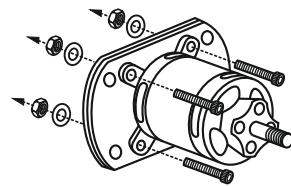

Attach the motor to the motor mounting and secure it in place using the four 3x20mm bolts and nuts.

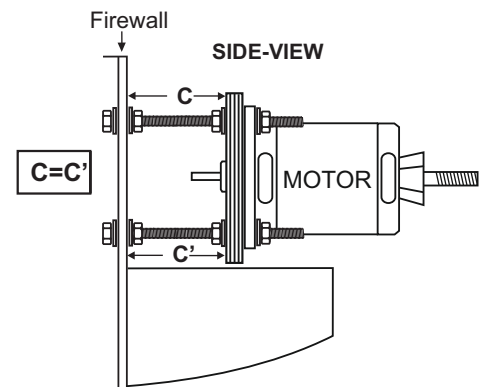
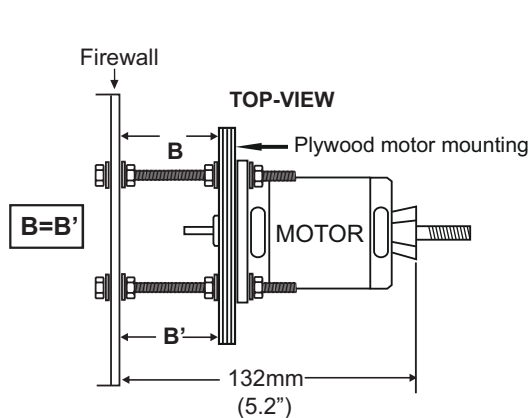
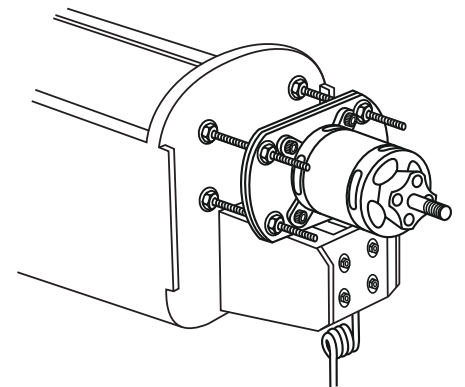

! Engine thrust on balk head is already adjust at factory

- 6x100mm bolt.....4
- 6mm nut.....12
- 6mm washer...16

## 14-Cowling

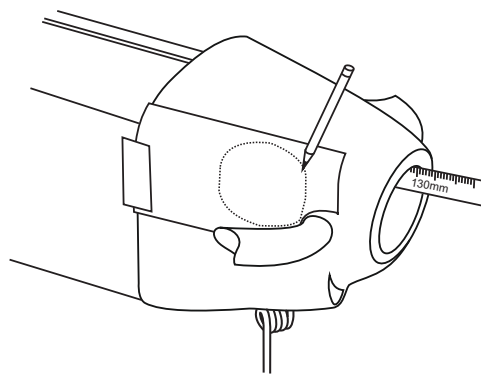
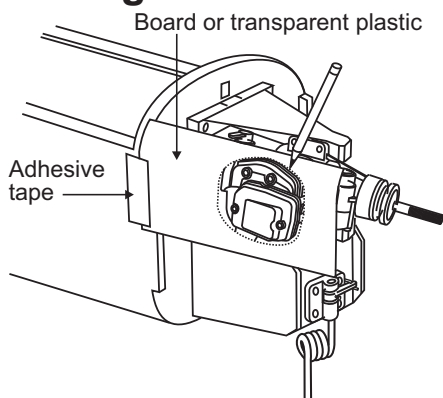

Cut the opening

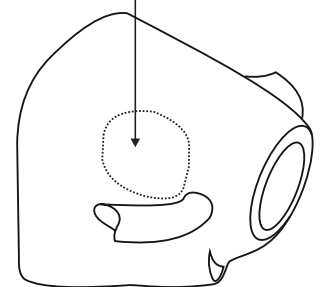

- 2.5x10mm screw  
.....3

- 1-Attach the board or transparent plastic on the side of the fuselage with the adhesive tape as show.
- 2-Using a pencil or felt tipped pen trace around the engine head where it meet the cowl. Cut the opening the board or transparent plastic for the engine head as marked before.
- 3-Remove the engine and insert the cowl on to the fuselage so the distance from the fire wall to the front of the cowl is 5.1"(130mm). Trace around inside the hole on the board or transparent plastic with a pencil.
- 4-Remove the cowl from the fuselage and carefully cut the opening for the engine head as marked above. Do the same way with the hole for needle-valve.
- 5-Again. Insert the cowl on to the fuselage and secure it in place with five 2.5x10mm self tapping screws.



## 15-Canopy

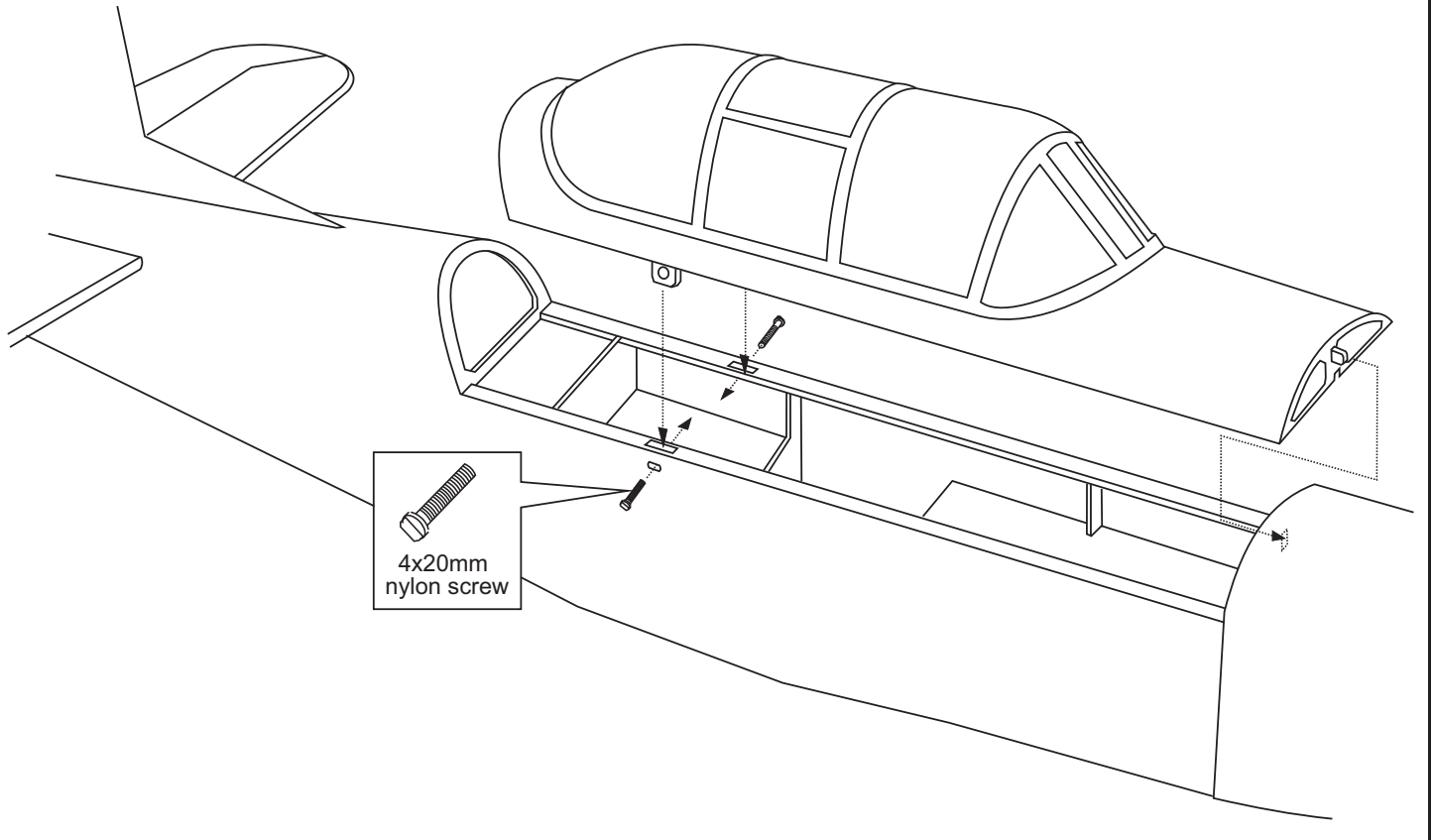

## 16-Servo

FUSELAGE - TOP VIEW

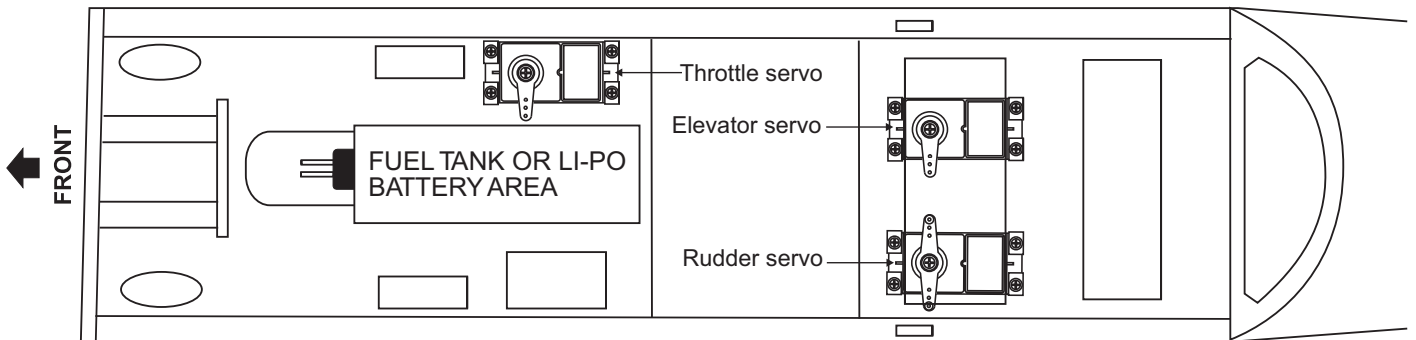

Shift the location of the fuel tank, battery pack, or Li-po battery as needed to obtain the specified CG.

## 17-Linkages

FUSELAGE - TOP VIEW

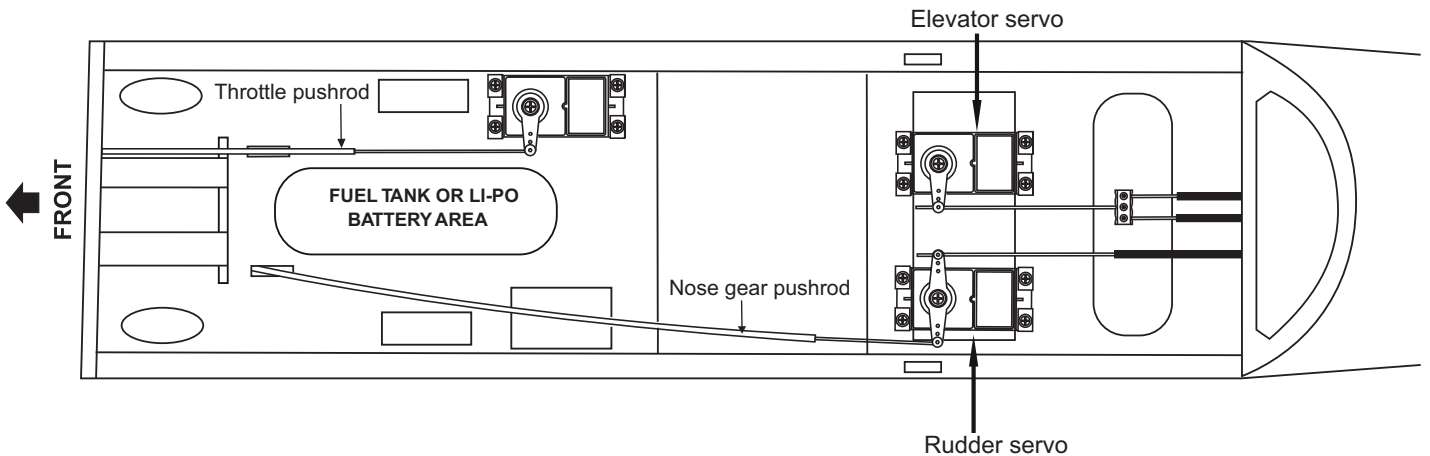

# 18-Linkages

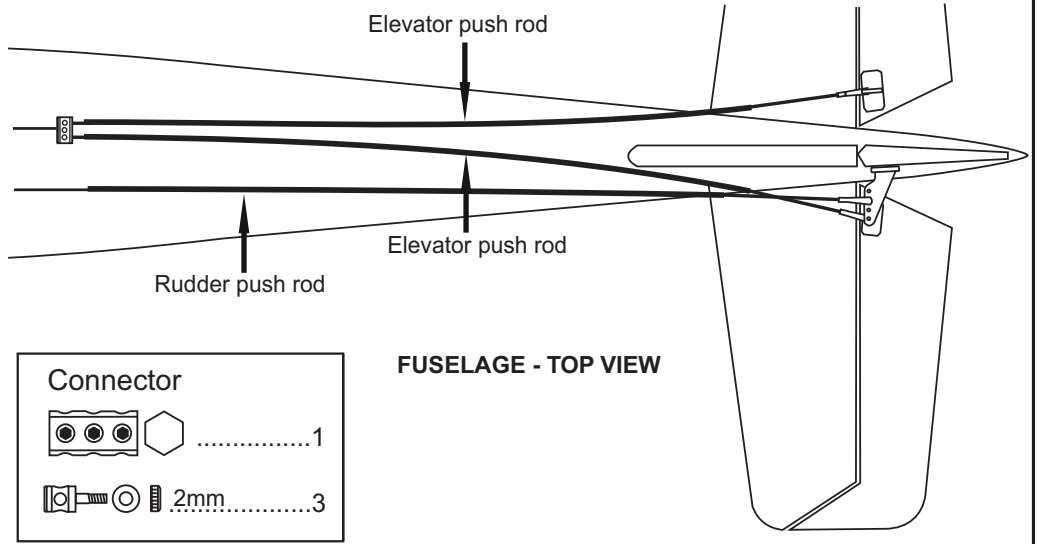
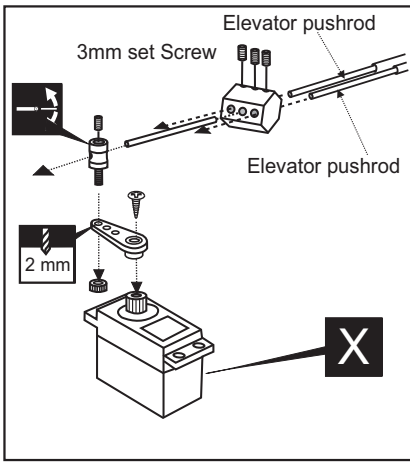

Connector

	.....1
	.....3

2mm

# 19-Installation the Wing

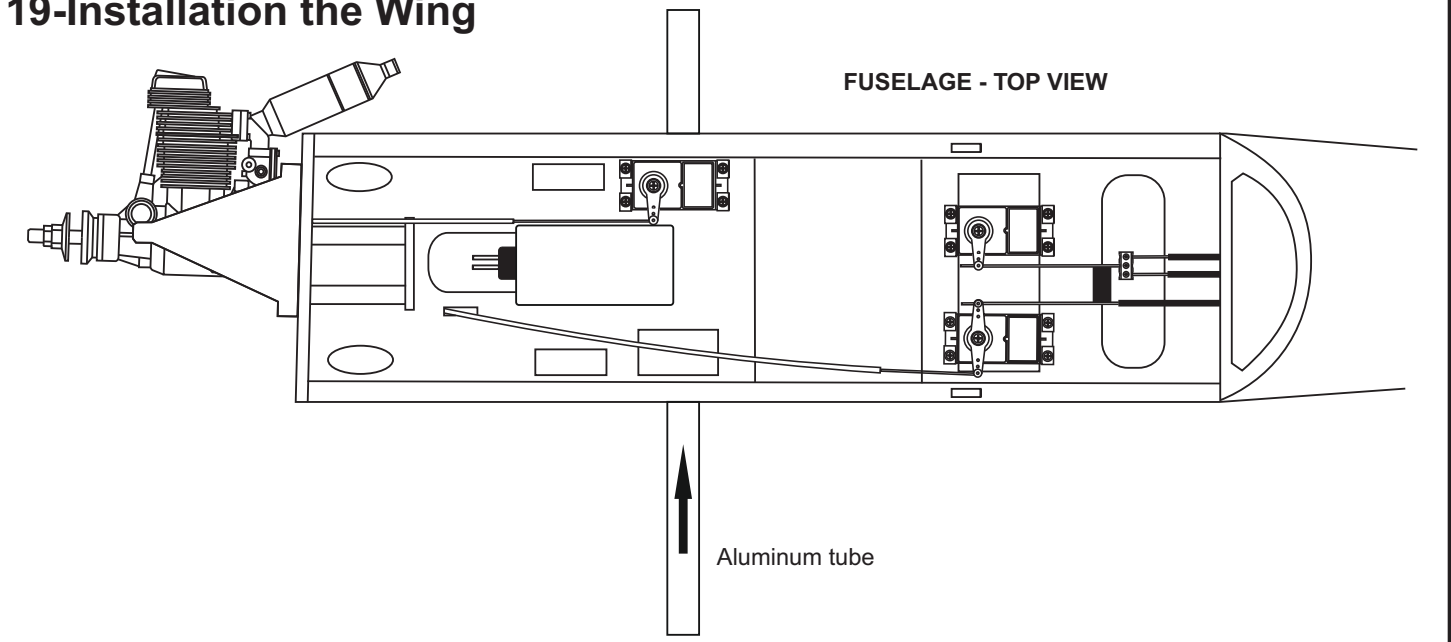

# 20-Installation the Wing

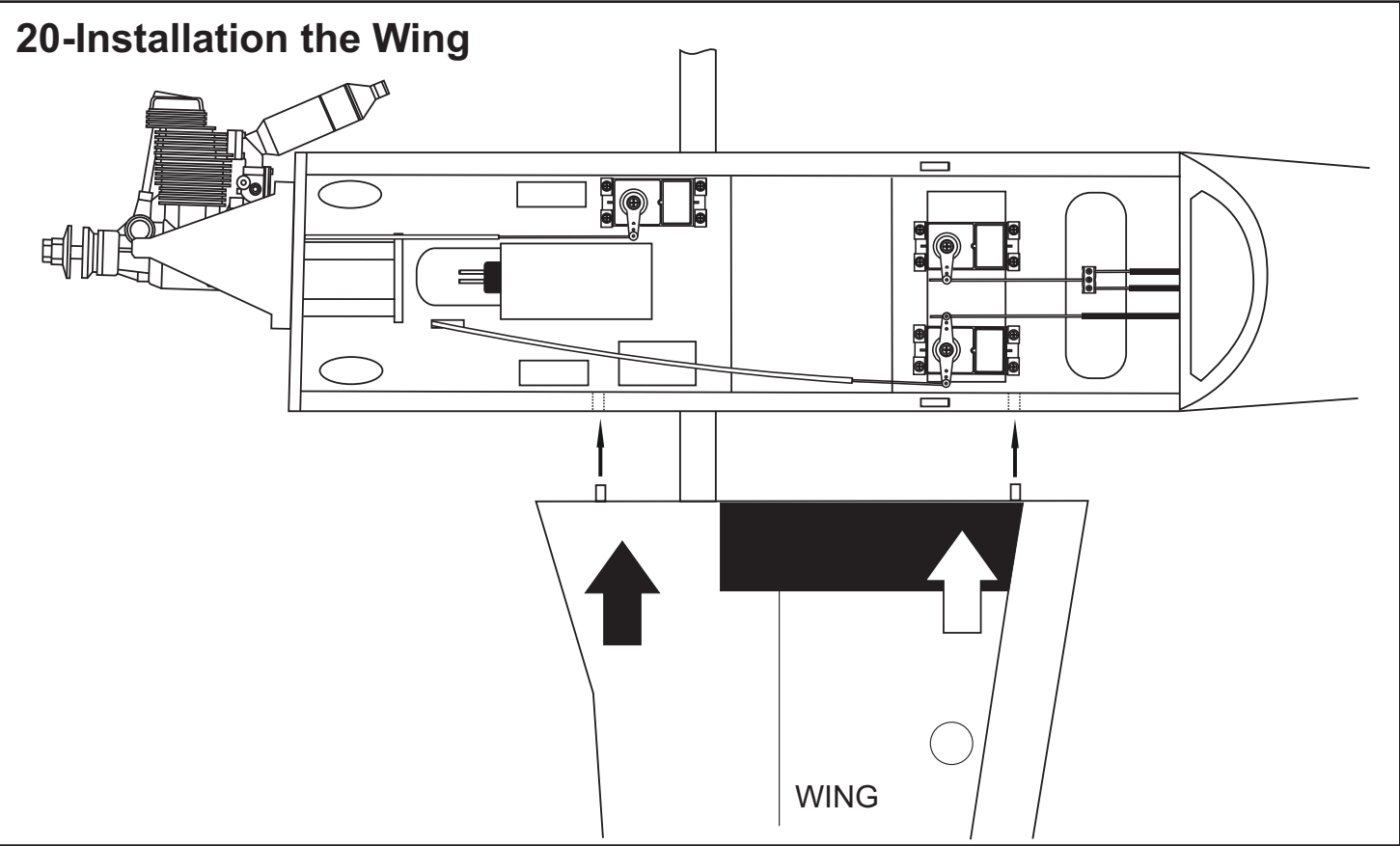

## 21-Installation the wing

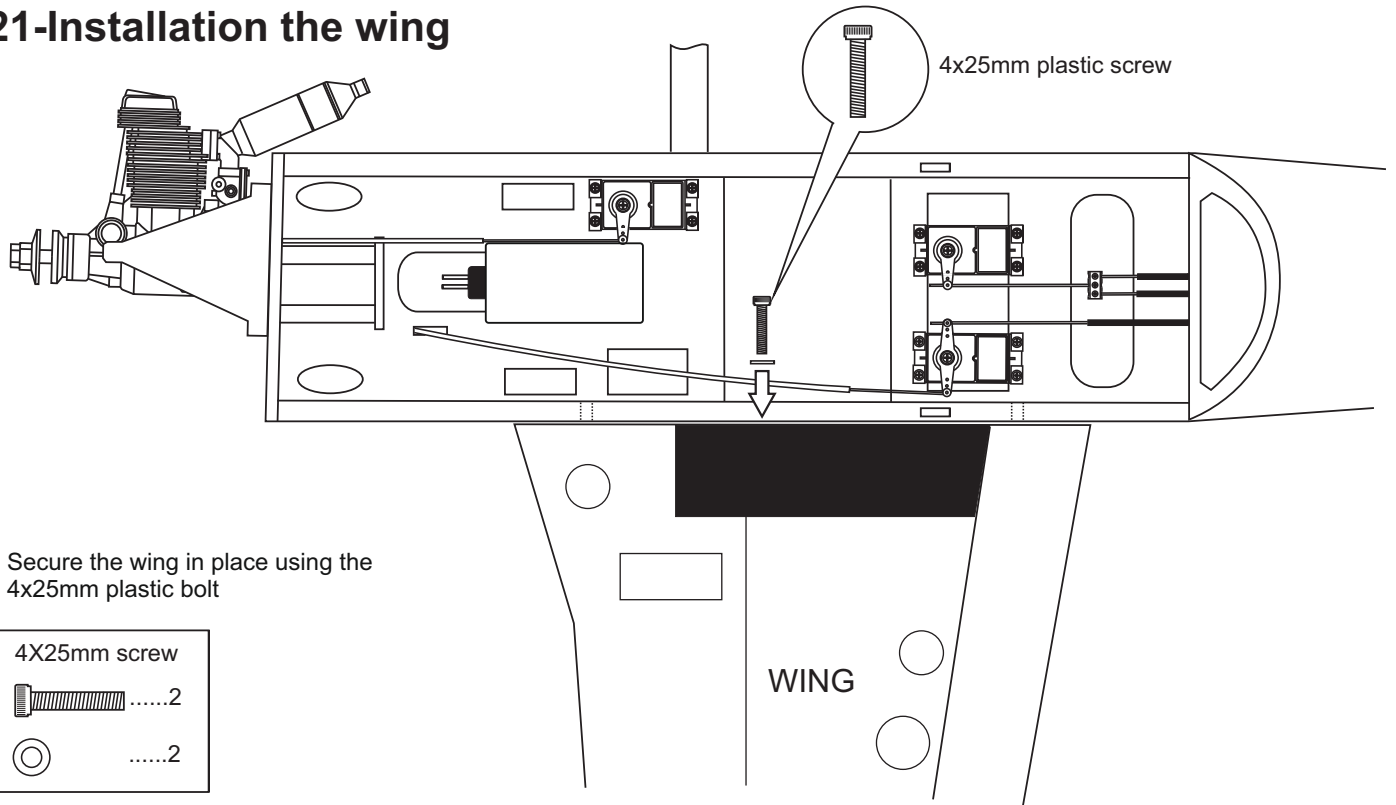

## 22-Decor

Cut away only the covering

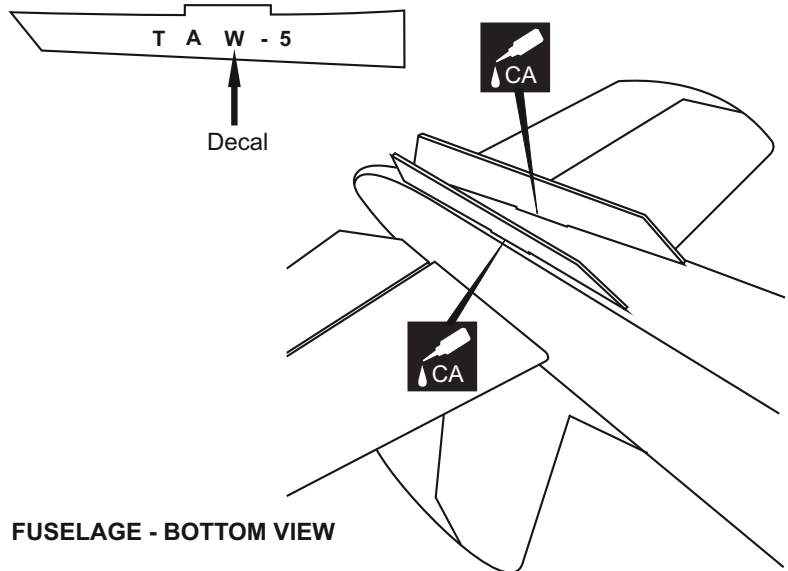
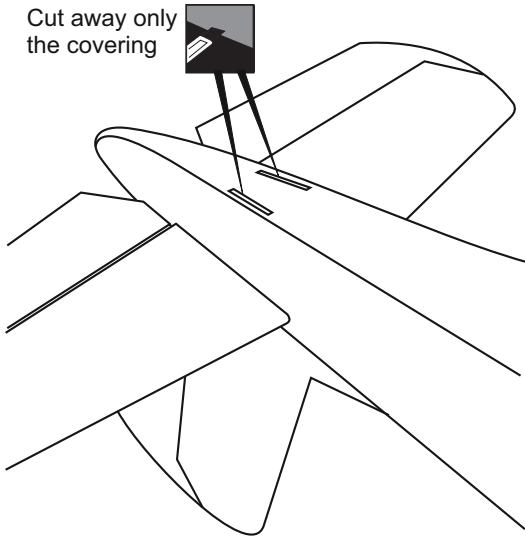

### Nose Gear door installation

Note: Glue the Right and Left gear door on to the cowl only. Please do not glue them on to the fuselage if you want to remove the cowl out of the fuselage.

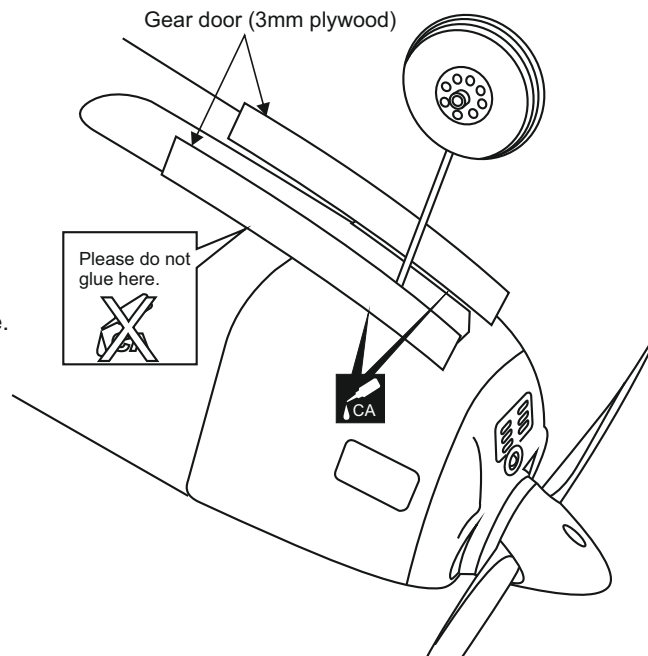

## 23-Decal

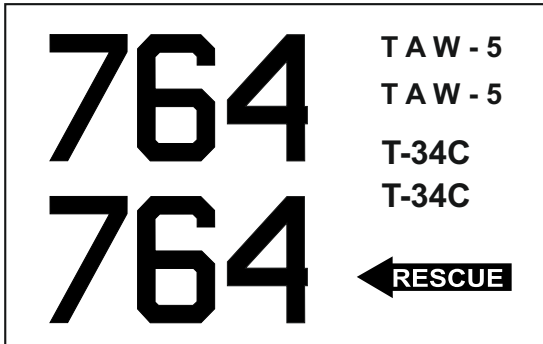

Note: Cut out the stickers and apply them in the proper area. Do not peel the backing paper off all at once. Peel off one corner of the backing and cut off with scissors. Arrange sticker on model and when satisfied adhere the corner without backing. Carefully peel back the rest of the backing while at the same time adhering the rest of the sticker. Try not to make air bubbles, if there are some, carefully puncture sticker (center of bubble) but not model surface with the tip of the knife or sharp pin and squeeze out the air. At curves stretch sticker and apply a little heat so that no ceases occur. Cut off the excess that is produced.

## 24-Balance

**DO NOT try to fly an out-of-balance model !**

Note: If necessary, move the battery pack or add weight to either the tail or nose until the correct balance is achieved.

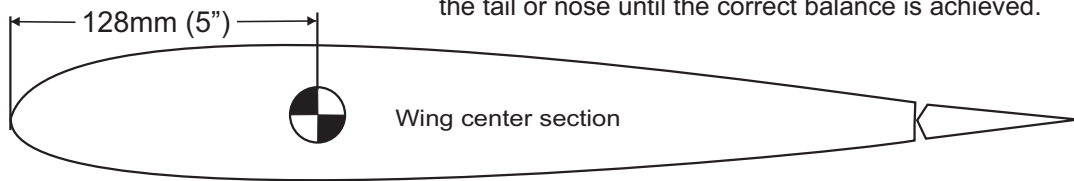

## 25-Control Surface

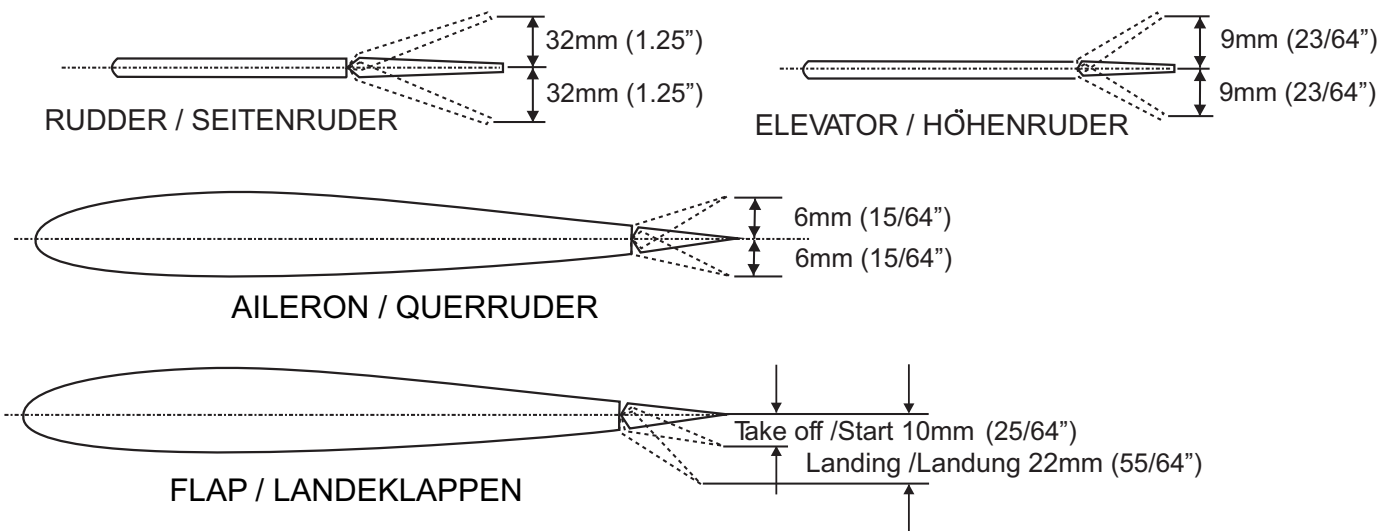

**IMPORTANT:** Please do not clean your model with pure alcohol, only use liquid soap with water or use glass cleaner to clean on surface of your model to keep the colour not fade.

All details are subject to changewithout notice !

**Technische Änderungen und Irrtümer vorbehalten !**